





INSTRUCCIONES DE ENSAMBLE

ASSEMBLY INSTRUCTIONS



* **Instrucciones de Instalación:** Mueble Viteli LVM 63 x 48 cm / mueble para el baño
Installation Instructions: Viteli cabinet 24.8" x 19" / bathroom sink cabinet

RECOMENDACIONES PREVIAS / Previous recommendations:

-  No golpee ni martille todo el mueble, sólo donde se le indica.
Do not strike or hammer all the cabinet, only where directed.
-  No pinte ni barnice el mueble.
Do not paint or varnish the cabinet.
-  No arrastre ni se suba al mueble, si necesita moverlo por favor levántelo.
Do not drag or stand on the cabinet, if you need to move it please lift up.
-  Lea detenidamente y siga en orden consecutivo las instrucciones de armado.
Read carefully and follow in sequence the assembly instructions.
-  No expongas el mueble a la intemperie, ni al calor.
Do not expose the cabinet to the outdoors or the heat.

IMPORTANTE:

Antes de empezar a ensamblar el mueble, lea detenidamente las instrucciones. Arme el mueble sobre su caja, para no rayarlos. Si falta una parte o piensa que esta defectuosa no devuelva el mueble al almacén; le agradecemos llamar al **(5-74) 444 17 71**, o comuníquese con su asesor principal, también nos pueden escribir a servicioalcliente@firplak.com.

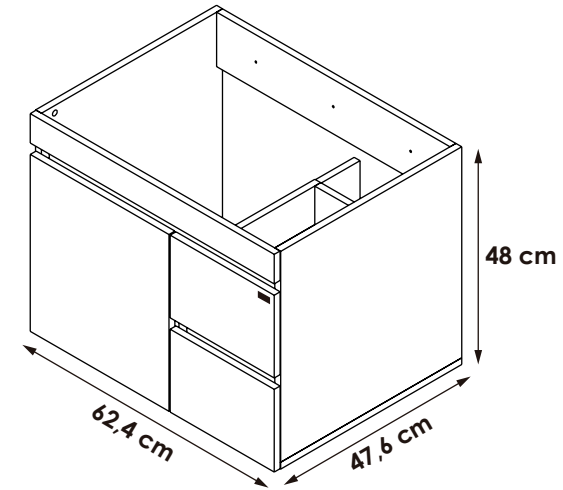

Sello de calidad / Quality seal

Por favor no deseche el instructivo del mueble, este le servirá para cualquier reclamo con respecto a la garantía del mismo.

Please do not discard the cabinet's instructions, it will serve you for any claim regarding its warranty.



IMPORTANT: *Before you start to assemble the cabinet, please read the instructions. Assemble the cabinet on its case, not scratched. If missing a part is defective or think you do not return the furniture to the store, please call the **(5-74) 444 17 71** or contact your principal advisor. also you can write to servicioalcliente@firplak.com.*

1. Identificación de las partes

Parts identification

HERRAMIENTAS REQUERIDAS / Tools required :

* No incluido.
Not included.

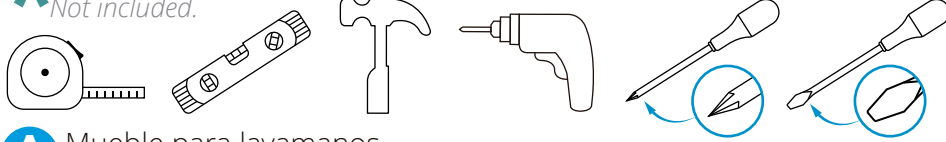

A Mueble para lavamanos.
Cabinet sink.



Tabla de piezas
Parts Chart

Pieza / Part	Cantidad / Total
A	1
B	1
C	1
D	1
E	1
F	1
G	1
H	1
I	1
J	1
K	1
L	1
M	1
N	1
Ñ	1
O	1
P	1
Q	1
R	1
Cantidad Total	Desde hasta
19	A R

B Identificación de herrajes.
Hardware identification

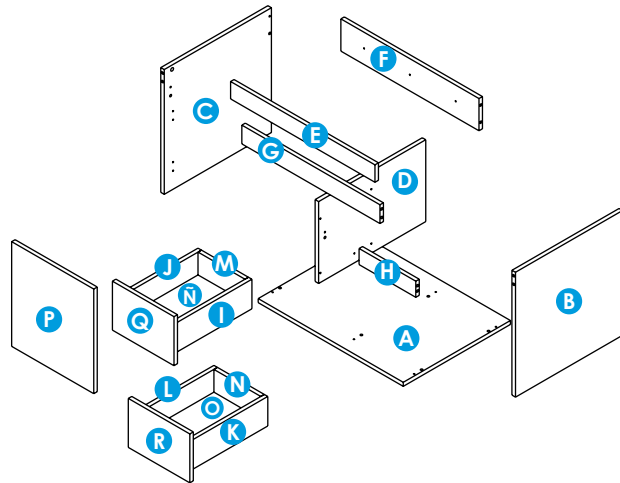
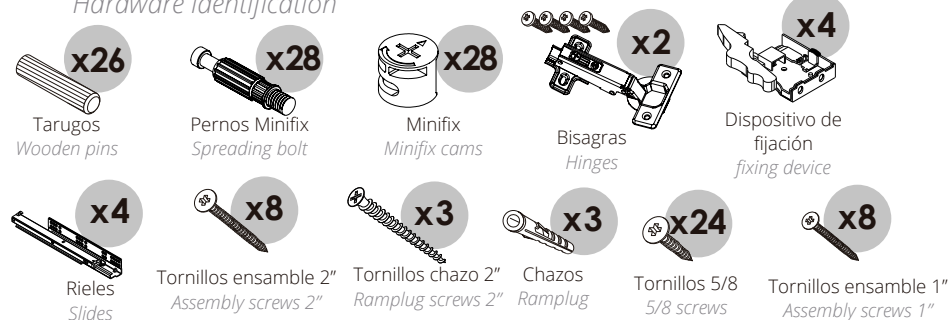

* Tenga precaución al abrir la bolsa de herrajes de no perder ningún elemento. Compruebe si el contenido de las piezas es el correcto; separe los herrajes en grupos para facilitar su identificación durante el armado.

Be carefull opening the screw bag so you do not lose any. Chek if the number of screws is right; Separate the screws into groups for easier identification during assembly.

C Recomendaciones de ensambles.
Assembly recommendations

Instalación de minifix y pernos de minifix

Installing the minifix cams and spreading minifix

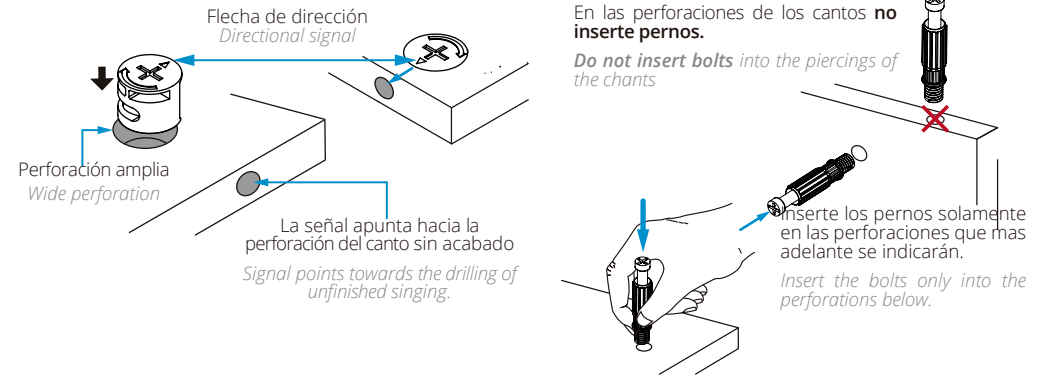

Ajustes de partes

Parts adjustments

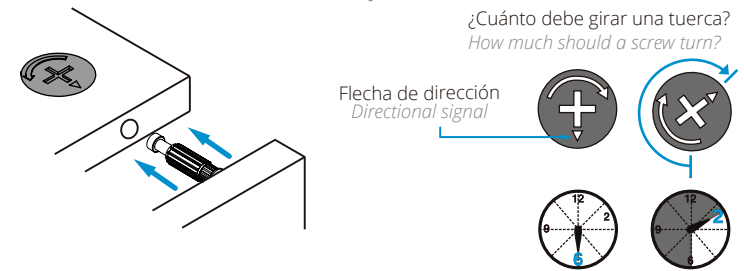

Tarugos

Wooden pins

Introduzca los tarugos solo hasta la mitad.
Insert the wooden pins only halfway

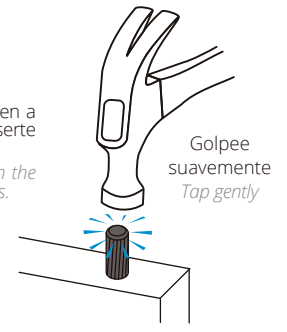
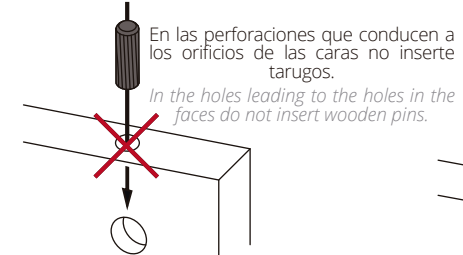
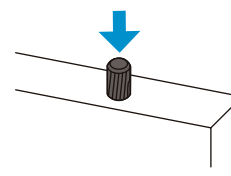

2. Preparación de las partes

Preparation of the parts

Se recomienda preparar las partes del mueble sobre la caja o una superficie lisa para no rayarlo.

It is recommended to prepare the parts of the cabinet on the box or on a flat surface to not scratch it.

Para este paso necesitarás:

For this step you will need:

Herramientas

Tools

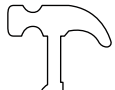

Martillo
Hammer



Destornillador de estrella
Star screwdriver

Herrajes

Fittings

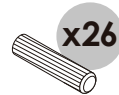

x26

Tarugos
Wooden pins

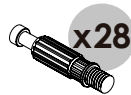

x28

Pernos Minifix
Spreading bolt



x28

Minifix
Minifix cams

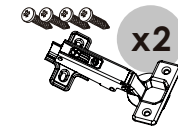

x2

Bisagras
Hinges

1

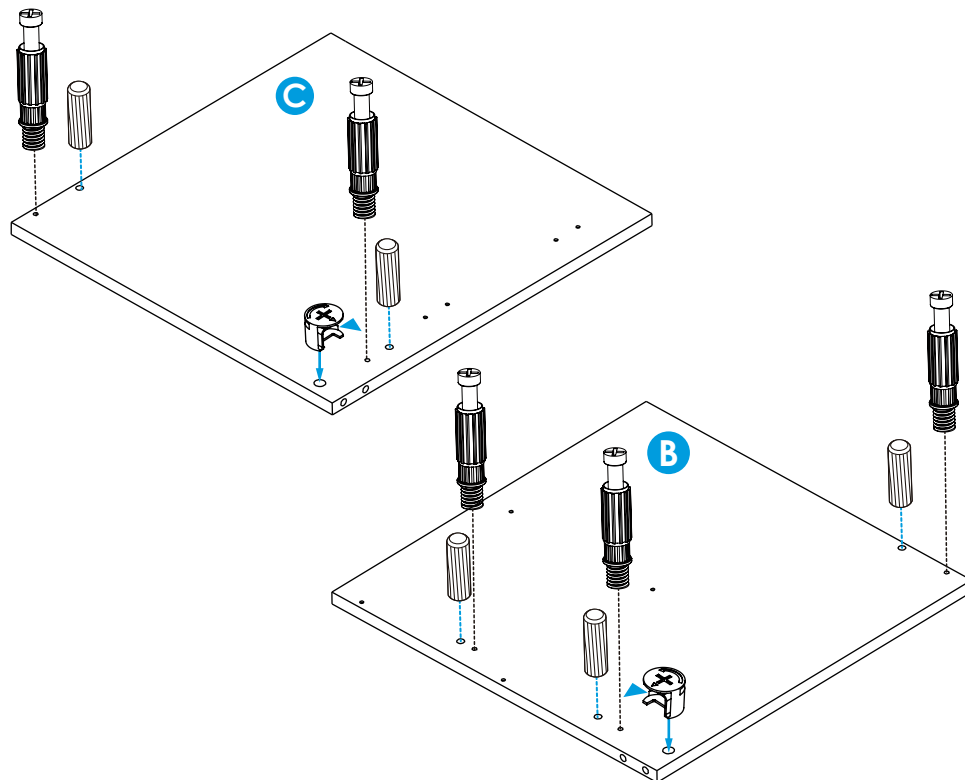

2

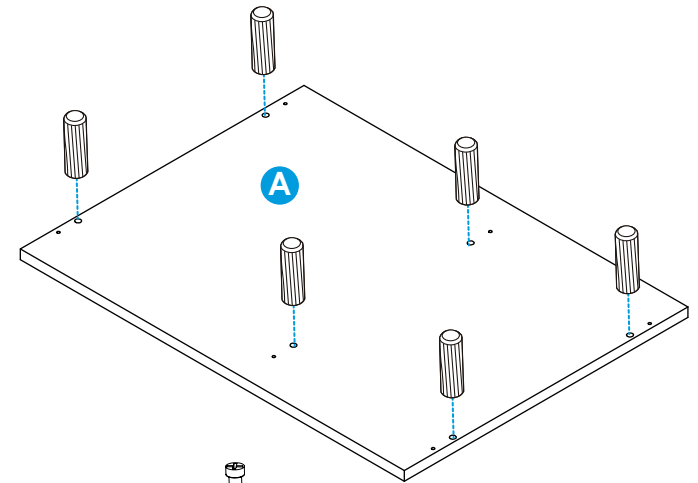

3

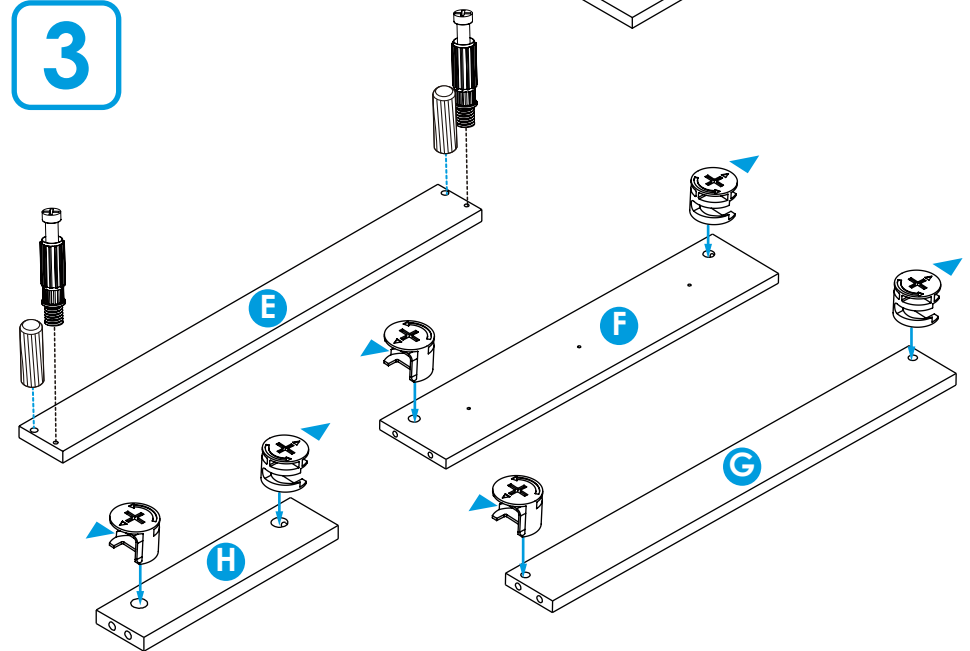

4

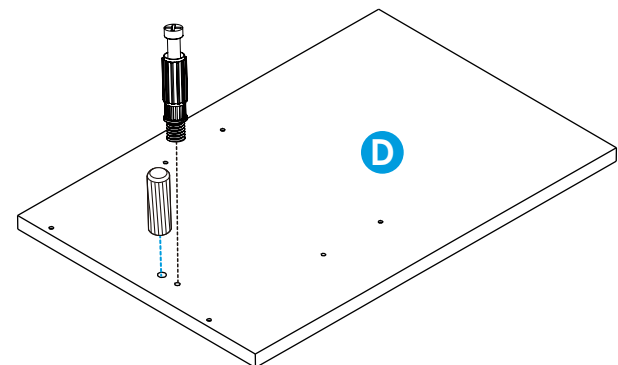

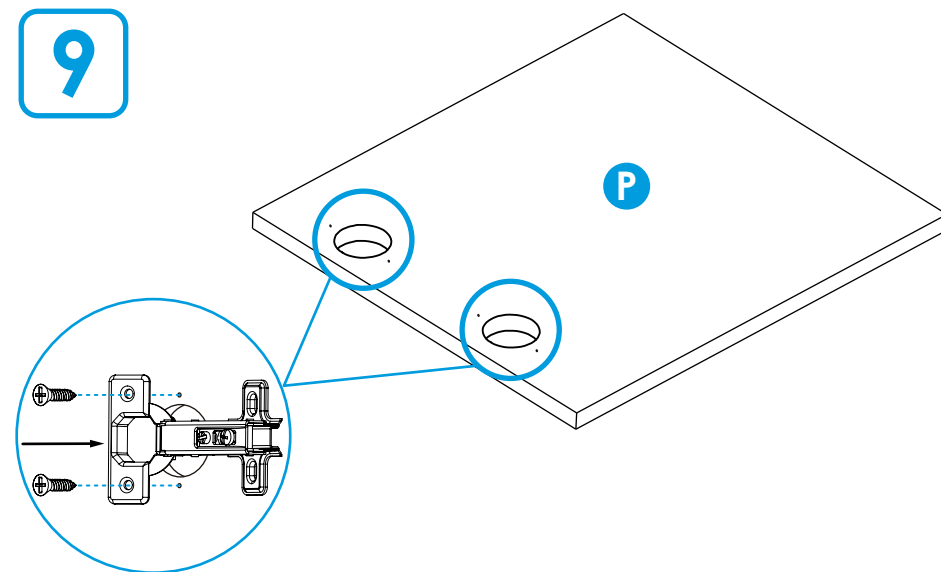
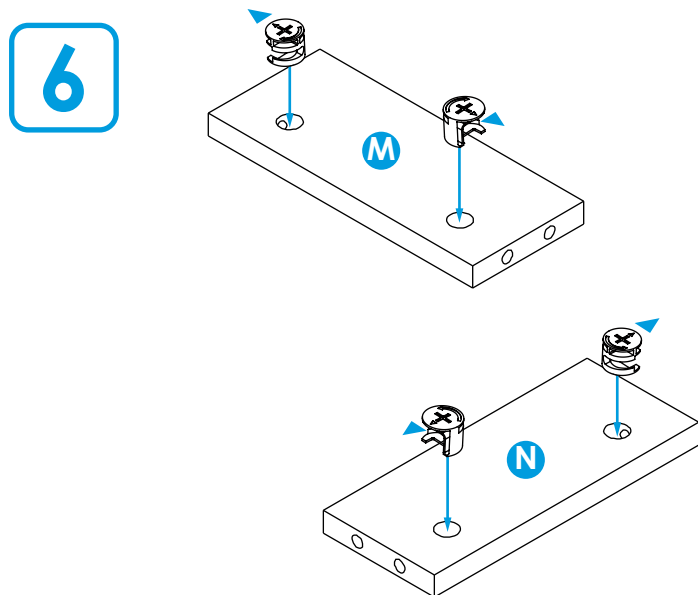
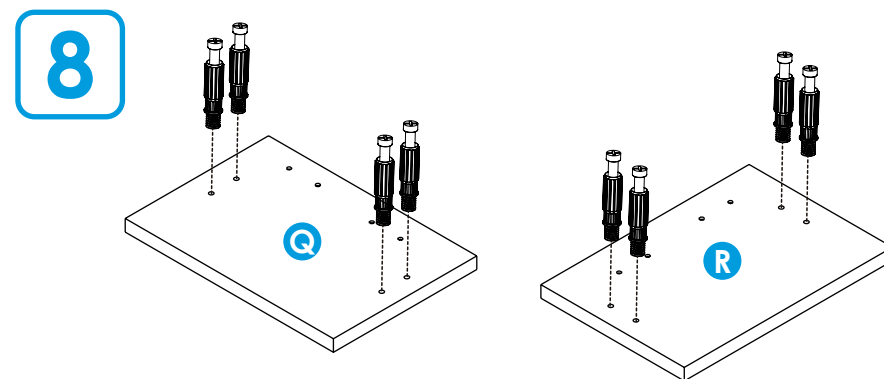
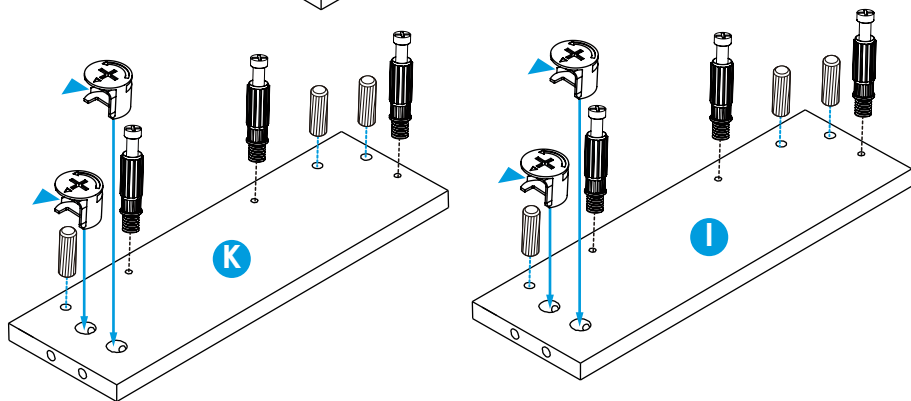
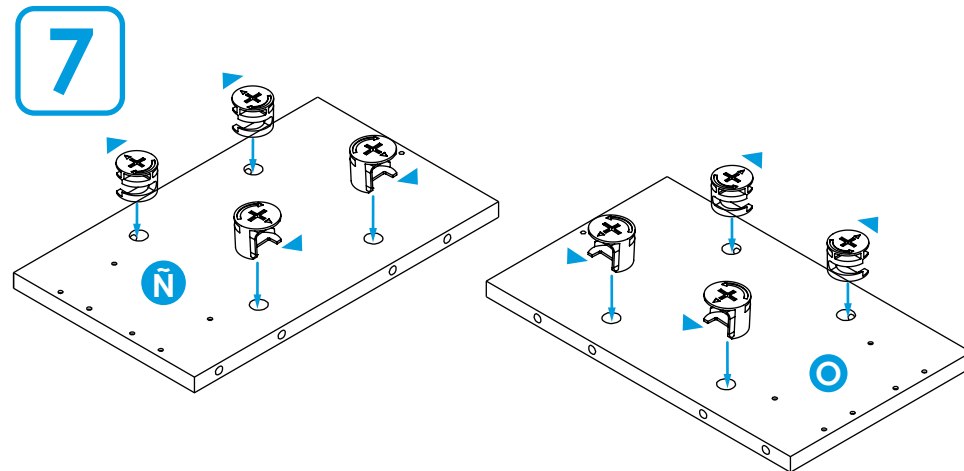
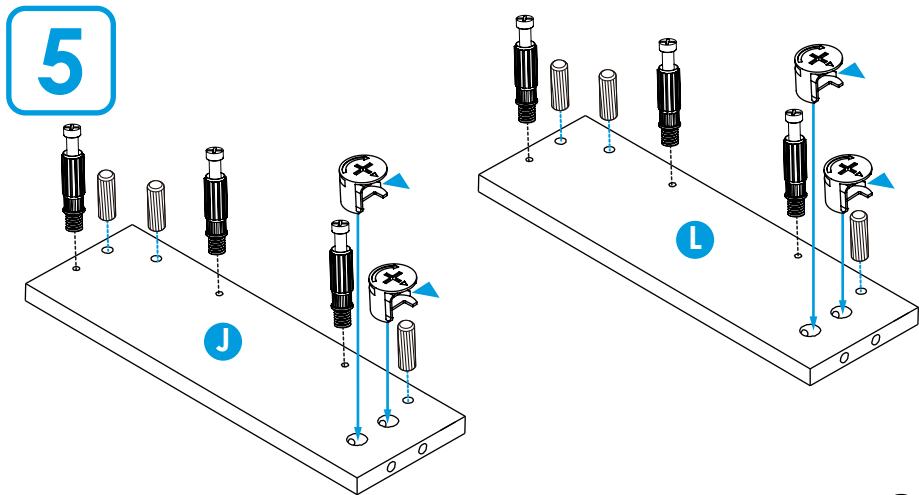

3. Preparación para ensamblar

Assembly steps

✦ Se recomienda armar el mueble sobre la caja o una superficie lisa para no rayarlo.

Is recommended to assemble the product top of the box or on a flat surface to not scratch it.

Para este paso necesitarás:

For this step you will need:

Herramientas

Tools

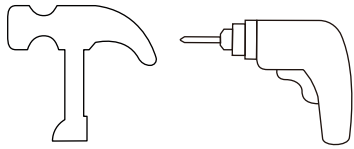

Martillo
Hammer

Taladro
Drill



Destornillador de estrella
Star screwdriver



Tornillos ensamblado 2"
Assembly screws 2"

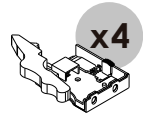

Dispositivo de fijación
fixing device

Herrajes

Hardware



Tornillos 5/8
5/8 screws

Rieles
Slides



Tornillos ensamblado 1"
Assembly screws 1"

2

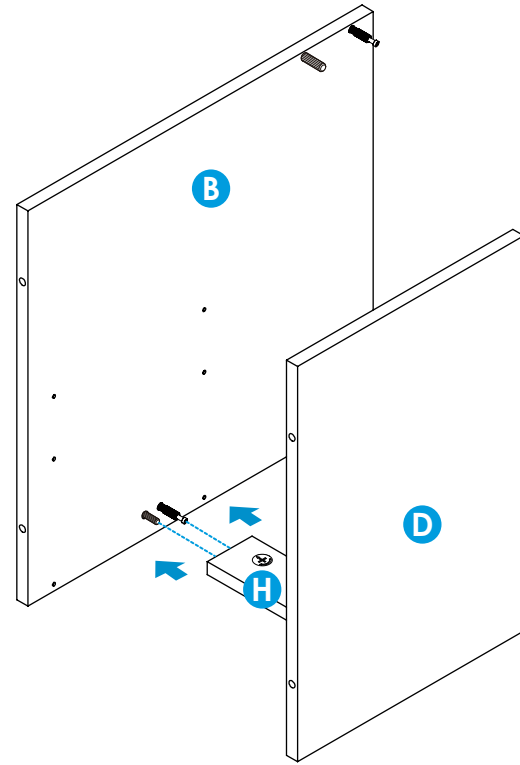

3

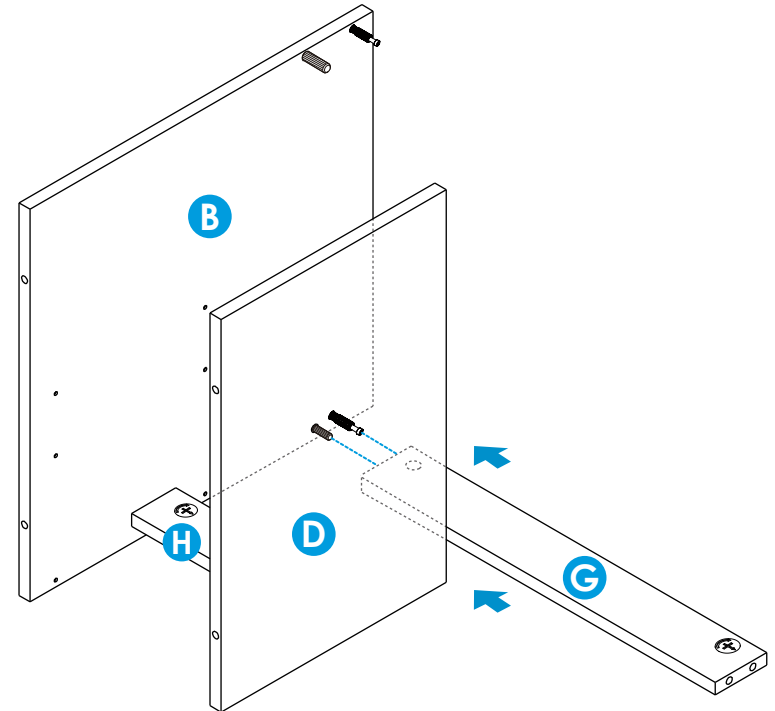

1

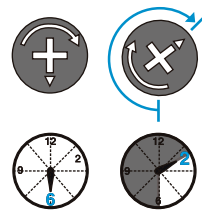
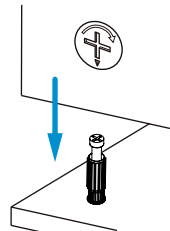
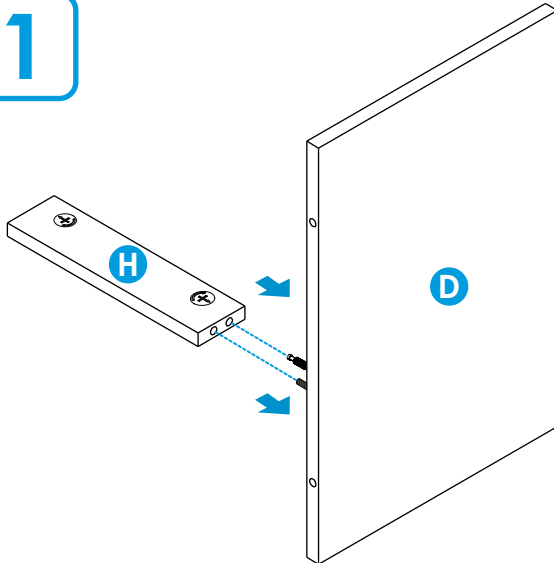

IMPORTANTE:

A medida que vaya encajando las piezas, ajuste con el destornillador.

IMPORTANT:

as the pieces fit together, adjust with the screwdriver.

IMPORTANTE:

De un correcto armado de los muebles depende su buen funcionamiento.

IMPORTANT:

A proper assembly of the furniture guarantees the performance of the hinges.

4

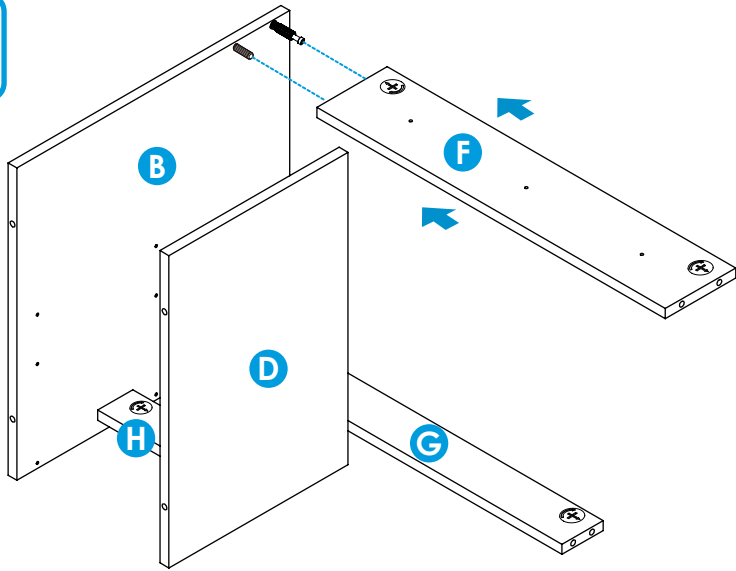

5

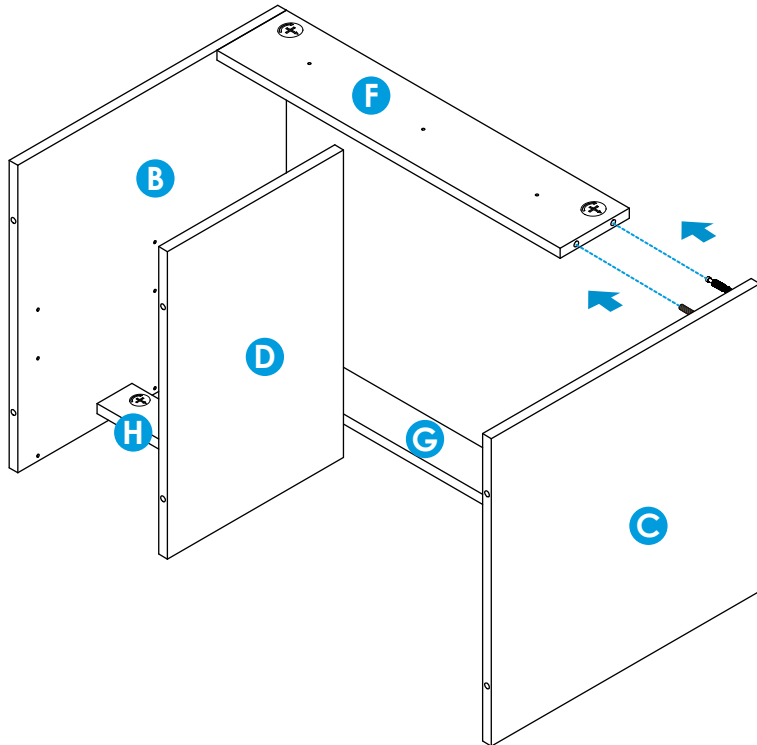

6

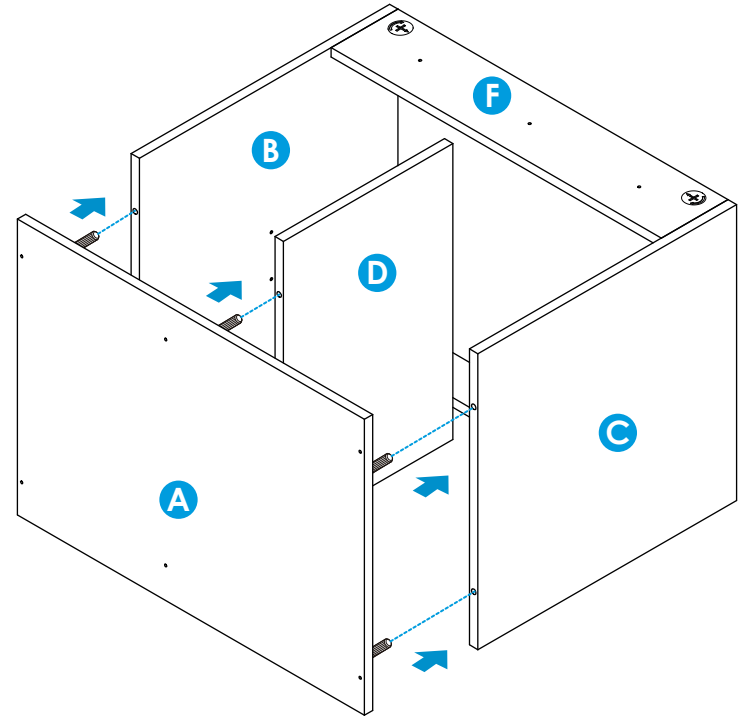

7

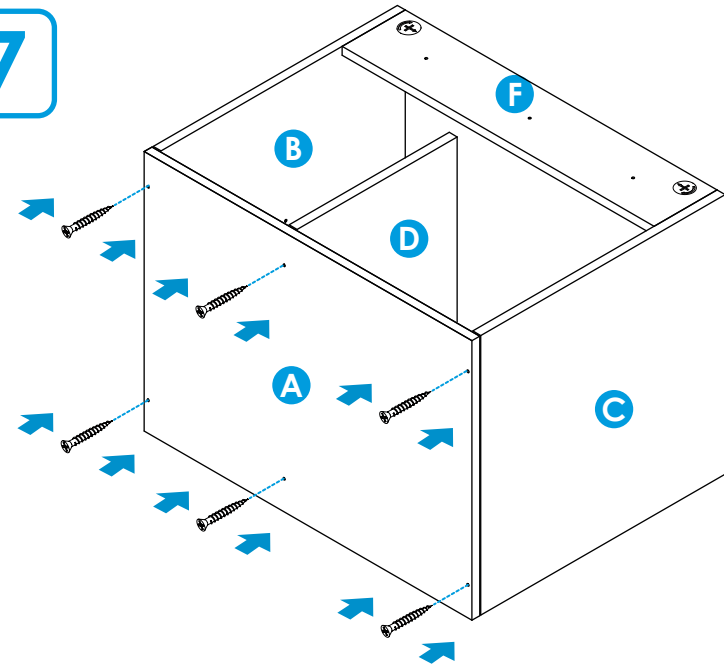

8

Girar mueble sobre su costado izquierdo.
Turn cabinet on the left side.

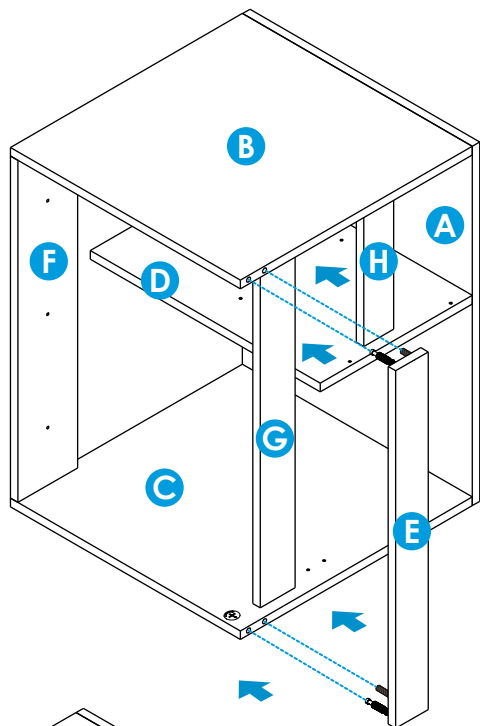

9

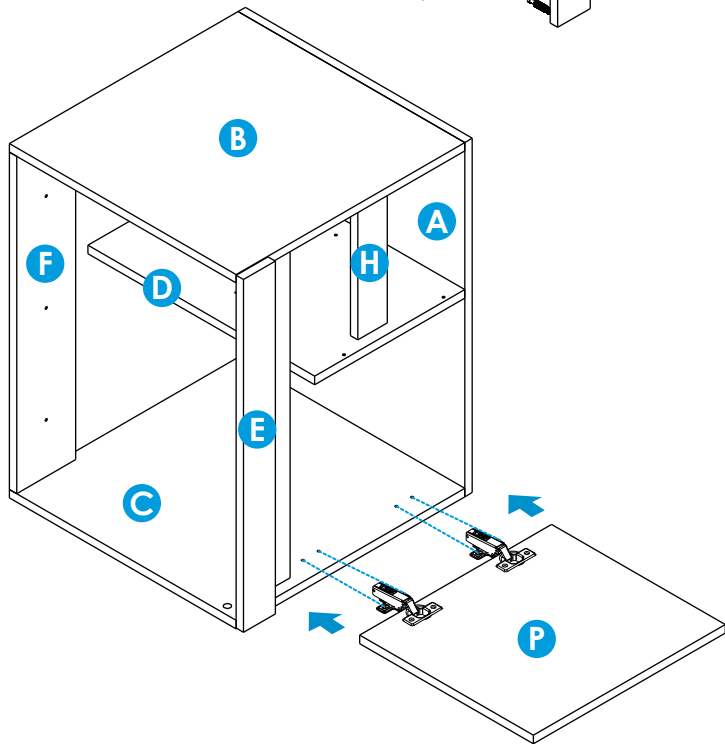

10

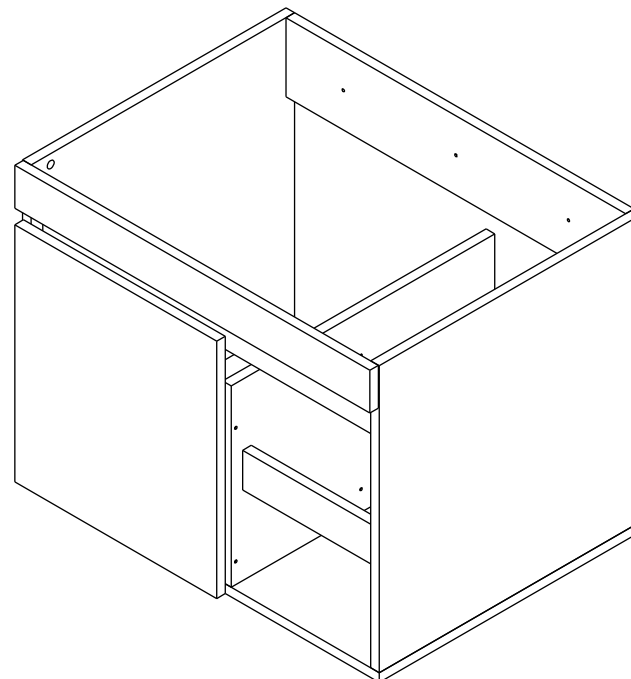

Ensamble cajones

Drawers assembly

* Se recomienda armar el cajón sobre la caja o una superficie lisa para no rayarlo.

It is recommended to assemble the drawer top of the box or on a flat surface to not scratch it.

Para este paso necesitarás:

For this step you will need:

Herramientas

Tools

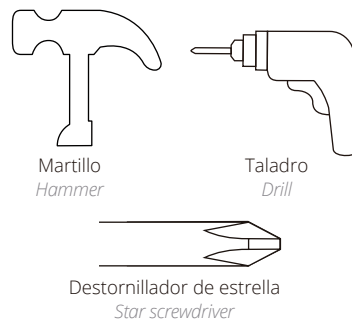

Herrajes

Hardware



Tornillos ensamble 2"
Assembly screws 2"



Tornillos 5/8
5/8 screws

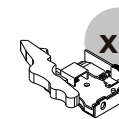

Dispositivo de fijación
fixing device



Rieles
Slides

10 Cajón superior.
Upper drawer

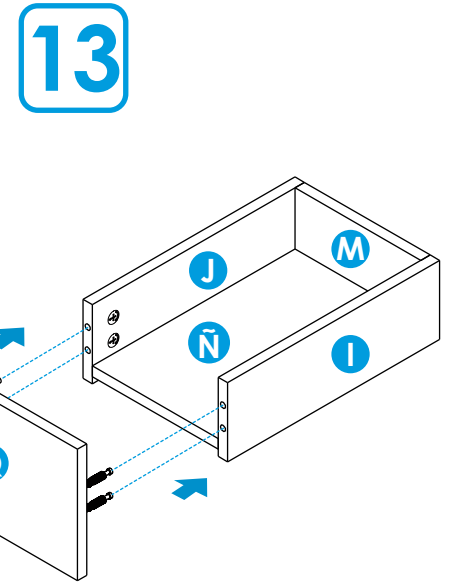
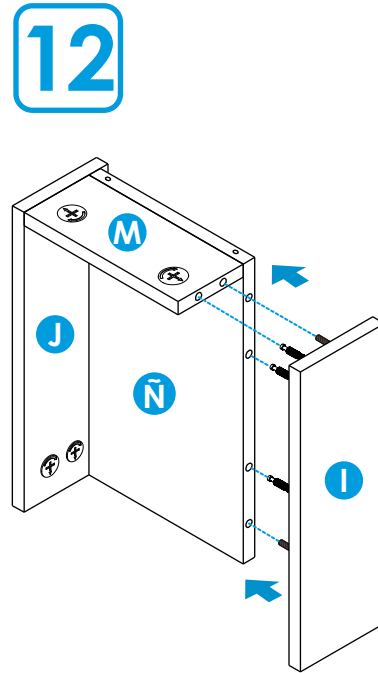
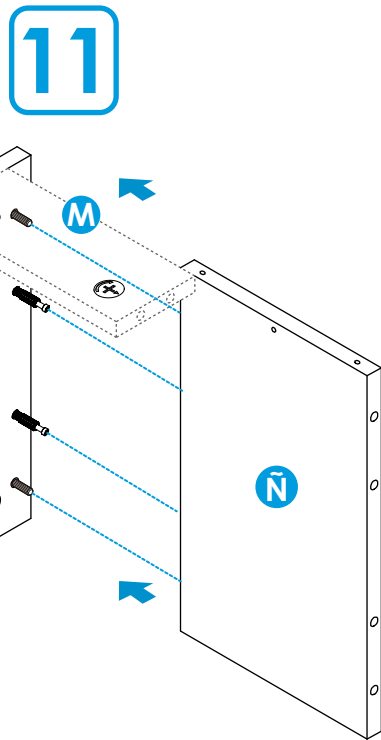
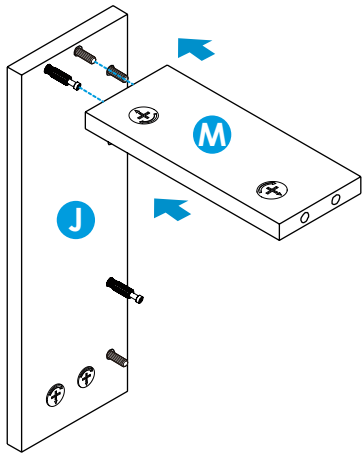

14 Cajón inferior.
Lower drawer

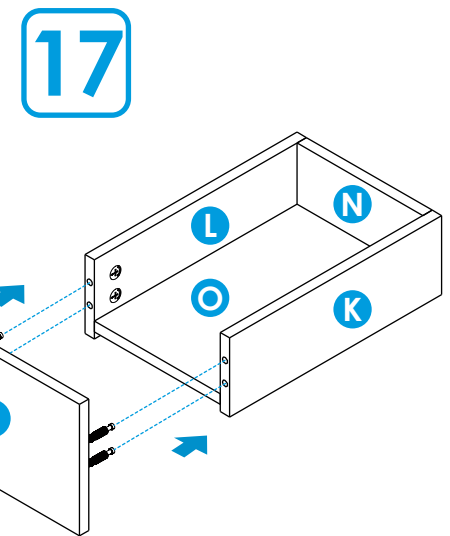
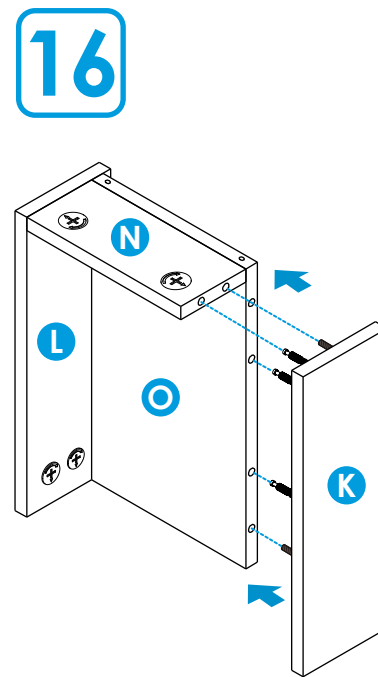
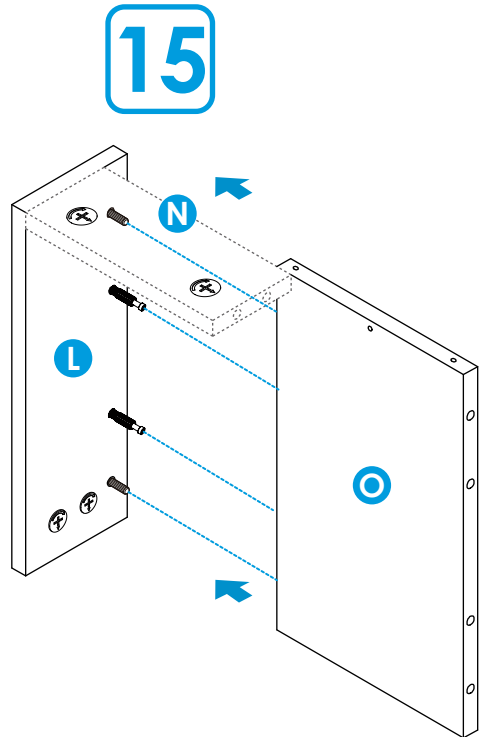
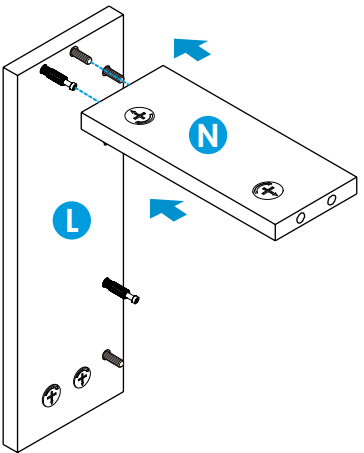

IMPORTANTE:
La pieza R corresponde al cajón inferior.
IMPORTANT:
the piece R corresponds to the lower drawer

18

Ensamble riel oculto.

Los rieles se ensamblan igual a ambos lados

Hidden rail assembly.

The rails are assembled equally on both sides.

Riel izquierdo.
Left rail.

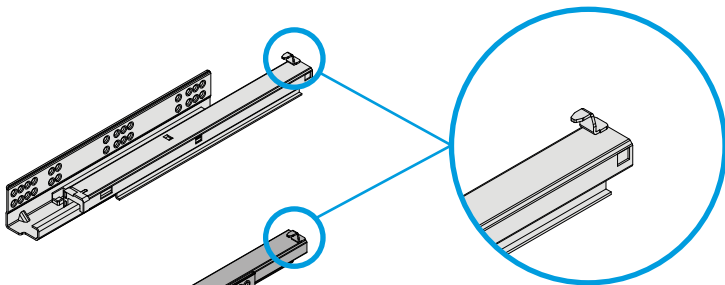

Riel derecho.
Right rail.

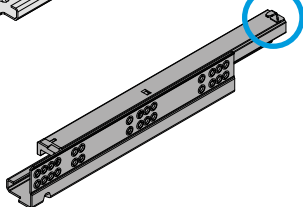

IMPORTANTE:
La pestaña va hacia atrás.

IMPORTANT:
The tab goes back.

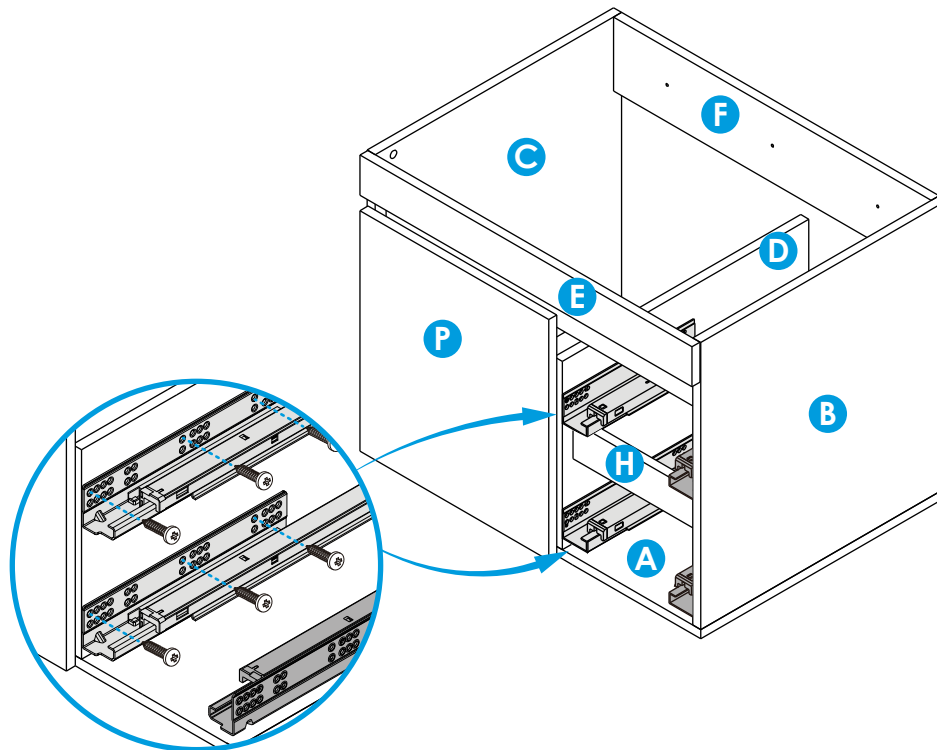

19

Instalación de el dispositivo de fijación debajo del cajón.

Installation of the fixing device under the drawer..

Para este paso necesitarás:
For this step you will need:

Herramientas *Tools*

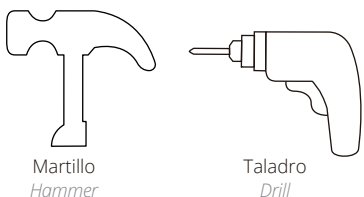

Martillo
Hammer

Taladro
Drill



Destornillador de estrella
Star screwdriver

Herrajes *Hardware*



x2
Tornillos ensamble 2"
Assembly screws 2"



x24
Tornillos 5/8
5/8 screws

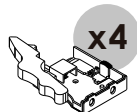

x4
Dispositivo de fijación
fixing device



x8
Tornillos ensamble 1"
Assembly screws 1"

19 A

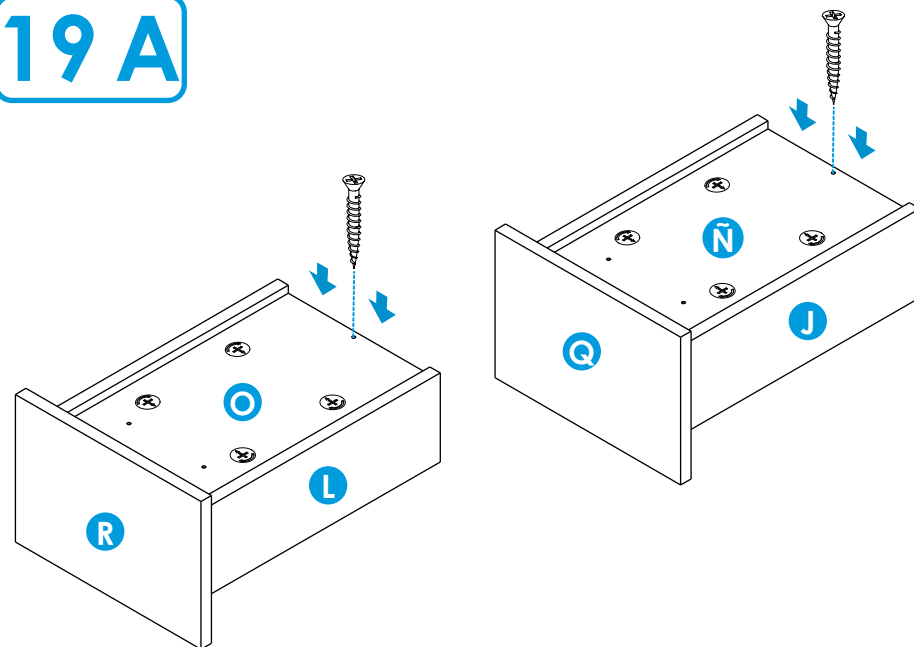

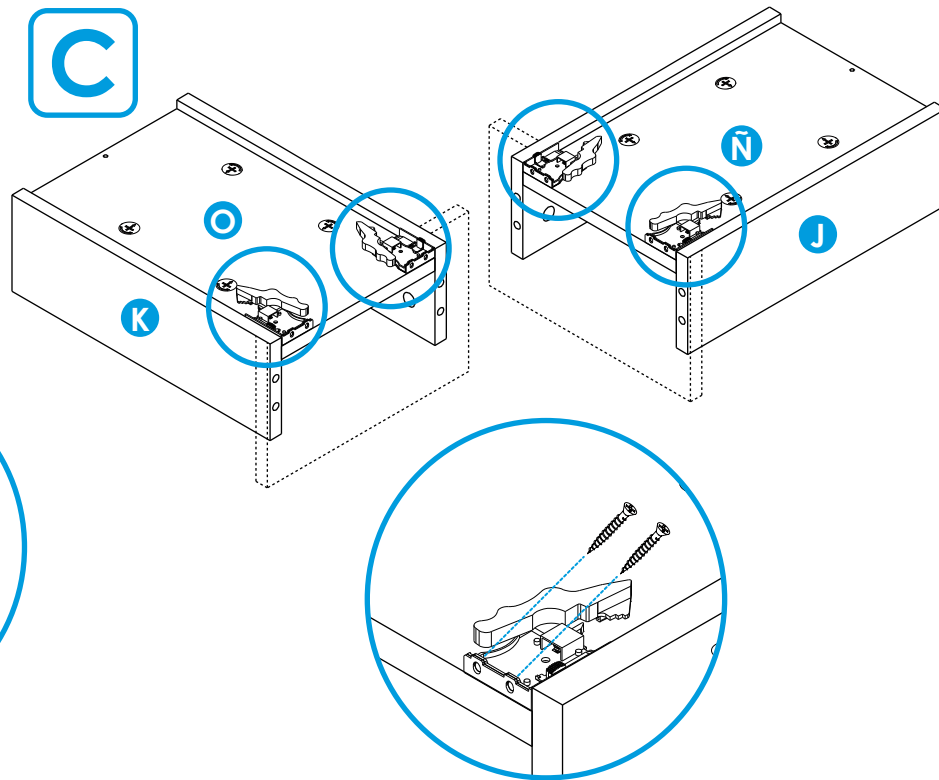
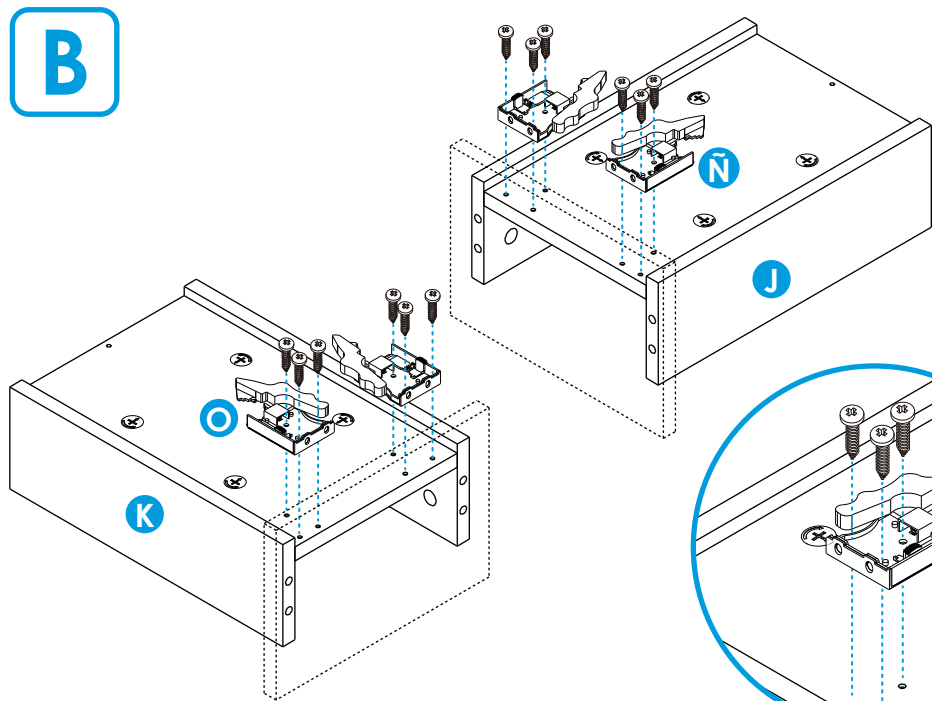

20 Introducir los cajones hasta sentir un "click".
Insert the drawers until you feel a "click"

21

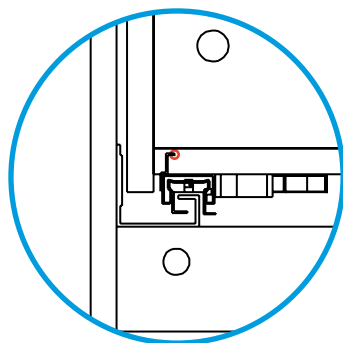
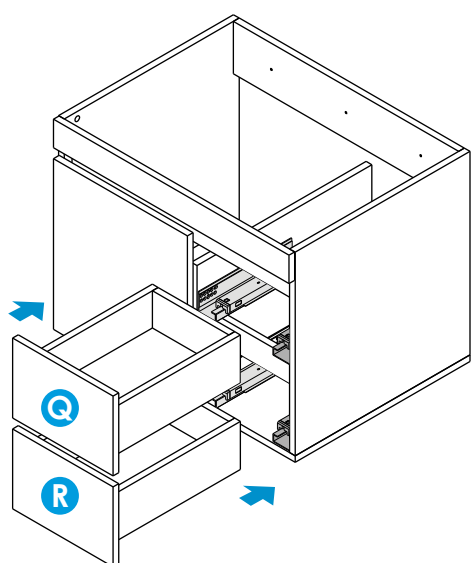

verifique que las pestañas estén dentro de las perforaciones realizadas.
check that the tabs are inside the drilled holes.

IMPORTANTE:

Para ajustar los cajones de forma correcta, por favor ver el siguiente vídeo ingresando en el link o escaneando el código QR.

IMPORTANT:

To adjust the drawers correctly, please watch the following video by entering the link or scanning the QR code

Link:

bit.ly/3Uk8qBs

Código QR - Code QR



Recomendación:

Para ver el contenido del código QR, usar el dispositivo móvil.

Recommendation:

To view the content of the QR code, use your mobile device.

* Mueble armado completamente Fully assembled cabinet

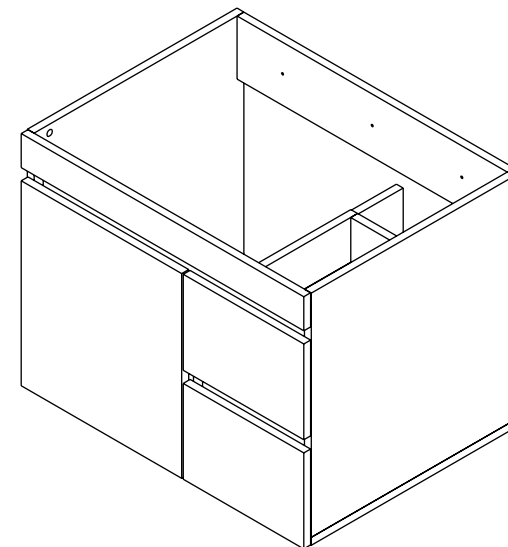

22

Para fijar el mueble: perfore la pared a la altura indicada de las perforaciones con ayuda de una broca para pared (tungsteno) 3/8", después introduzca el chazo plástico y asegure el mueble con tornillos chazos.

To secure the cabinet: drill the wall at the indicated height of the perforations with the help of a 3/8" wall bit (tungsten), then insert the plastic slab and secure the furniture with screws.

Para este paso necesitarás:

For this step you will need:

Herramientas

Tools

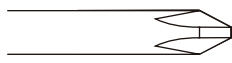

Destornillador de estrella
Star screwdriver

Herrajes

Fittings



Tornillos chazo 2"
Ramplug screws 2"



Chazos 2"
Ramplug 2"

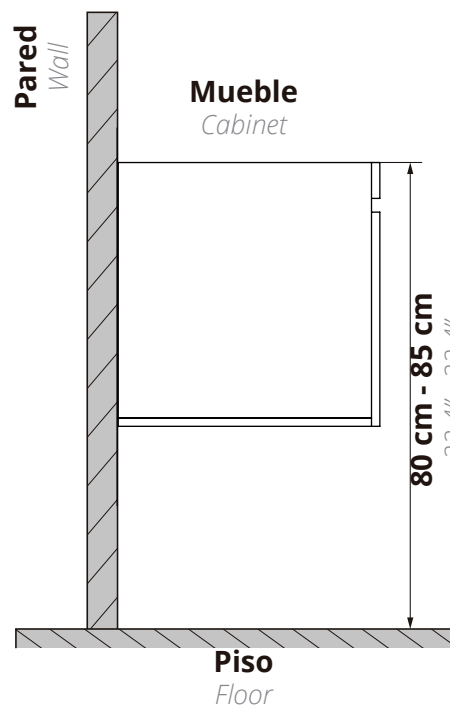

IMPORTANTE:

Tenga en cuenta que las paredes deben ser sólidas, de cemento / ladrillo. Si va a instalar el mueble sobre paredes de Drywall (paredes secas), debe utilizar chazos y tornillo de expansión metálico especial para drywall.

IMPORTANT:

note that the walls must be solid, cement / brick. In case of drywall installation, change the ramplug for a drywall metallic Spring Toggle.

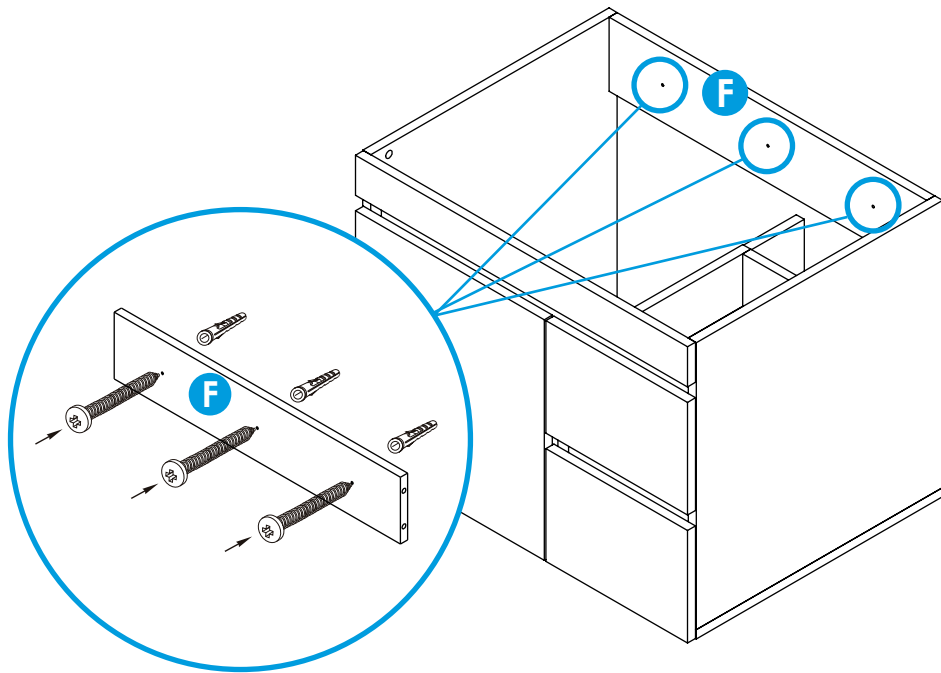

23 Ajuste y nivelación de puerta

Door adjustment and leveling

A. Nivelar: Para nivelar las puertas cuadrándolas al nivel deseado, afloje el tornillo de la bisagra, como lo muestra el detalle. Cuando esté en el lugar indicado, asegure los tornillos bisagra.

A. Level: To level the doors, to meet the desired level, loosen the hinge screw, as shown in detail. When in the right place, secure the hinge screws.

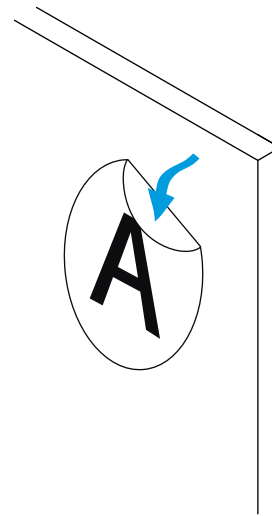
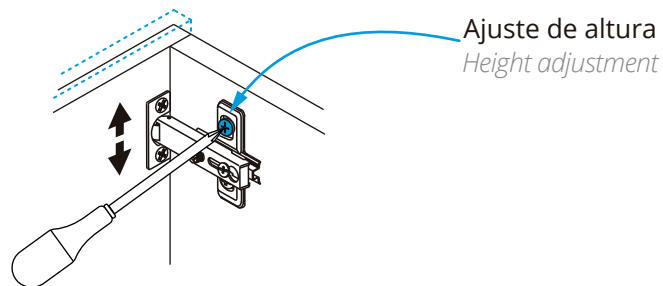

Al terminar de armar desprenda los adhesivos (en caso de que queden residuos de pegante, limpie la superficie con alcohol).

When you finish assembling, remove the adhesives (in case there is glue residue, clean the surface with alcohol).

B. Ajuste de profundidad: le permite llevar las puertas hacia dentro o hacia afuera, aflojando el tornillo de la bisagra, como lo muestra el detalle.

B. Depth adjustment: allows you to move the doors in or out, loosening the hinge screw as shown in detail.

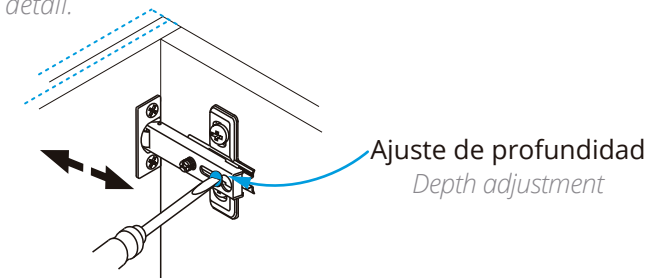

C. Ajuste lateral: le permite llevar las puertas hacia la derecha o la izquierda, nivelándola con los laterales aflojando o apretando el tornillo de la bisagra como lo muestra el detalle.

C. Side adjustment: Allows you to move the doors to the right or left, leveling with the sides loosening or tightening the hinge screw as shown by the detail.

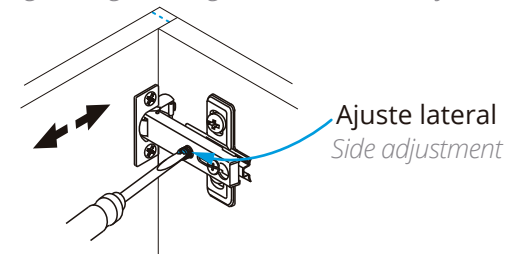

24**GARANTÍA:**

Para obtener más información sobre la garantía de los muebles, ingrese al enlace o escanee el código QR.

WARRANTY:

For more information on the furniture warranty, please enter the link or scan the QR code.

Link:
<https://bit.ly/3nf4W6x>

Código QR - Code QR

**Importante:**

Consulte la garantía antes de hacer una reclamación.

Important:

Check the warranty before making a claim.

4. Cuidados y mantenimiento

Care and maintenance

Cuidados y mantenimiento para los muebles

- Para limpiar el mueble use un trapo seco o humedézcalo en agua y detergente suave, elimine el exceso de agua.
- No pinte ni barnice el mueble.
- No esponga el mueble a la intemperie.
- Evite arrastrarlo, puede ocasionar daños en la estructura.
- Por seguridad, evite que los menores jueguen con el mueble.
- No esponga el mueble a funciones diferentes para lo que fueron diseñados. Ejemplo: sentarse en el mueble.

Care and maintenance for cabinet

- *To clean the cabinet, use a dry cloth or moisten it in water and mild detergent.*
- *Do not paint or varnish the furniture.*
- *Do not expose the furniture to the out side.*
- *Avoid dragging it, it can cause damage to the structure.*
- *For safety, avoid children playing with the furniture.*
- *Do not expose the furniture to different functions for which they were not designed. Example: sit on the furniture.*

si necesita ayuda comuníquese con su asesor comercial firplak tel: 4441771 (ext: 108). tel: 4441771 (ext: 131)

if you need help, contact your business advisor firplak tel: 4441771 (ext: 131)



www.firplak.com

Sede principal: Calle 29 N° 41-15 (Itagüí - Antioquia), Teléfono: (574) 444 17 71